

Output Groups

Backplane

<i>PL-1746 Function Name</i>	<i>SLC 500 File Address</i>	<i>Mapping Index Number</i>	<i>Read/Write Capability</i>	<i>Valid Range for Data</i>
Group Quantity	M0:S.64	256	R/W*	1-6
Group Position Display	M0:S.65	258	R/W	0=EACH 1=ONE
Logic Inputs Status	M0:S.25	178	R/O	0-255
Group 0 Channel Count	M0:S.66	260	R/W*	0-32
Group 0 Mode	M0:S.82	292	R/W*	0-5
Group 0 Offset	M0:S.74	276	R/W	0 to (Scale Factor-1)
Group 0 Position	M0:S.16	160	R/W*	0 to (Scale Factor-1)
Group 1 Channel Count	M0:S.67	262	R/W*	0-32
Group 1 Mode	M0:S.83	294	R/W*	0-5
Group 1 Offset	M0:S.75	278	R/W	0 to (Scale Factor-1)
Group 1 Position	M0:S.17	162	R/W*	0 to (Scale Factor-1)
Group 2 Channel Count	M0:S.68	264	R/W*	0-32
Group 2 Mode	M0:S.84	296	R/W*	0-5
Group 2 Offset	M0:S.76	280	R/W	0 to (Scale Factor-1)
Group 2 Position	M0:S.18	164	R/W*	0 to (Scale Factor-1)
Group 3 Channel Count	M0:S.69	266	R/W*	0-32
Group 3 Mode	M0:S.85	298	R/W*	0-5
Group 3 Offset	M0:S.77	282	R/W	0 to (Scale Factor-1)
Group 3 Position	M0:S.19	166	R/W*	0 to (Scale Factor-1)
Group 4 Channel Count	M0:S.70	268	R/W*	0-32
Group 4 Mode	M0:S.86	300	R/W*	0-5
Group 4 Offset	M0:S.78	284	R/W	0 to (Scale Factor-1)
Group 4 Position	M0:S.20	168	R/W*	0 to (Scale Factor-1)
Group 5 Channel Count	M0:S.71	270	R/O	0-32
Group 5 Mode	M0:S.87	302	R/W*	0-5
Group 5 Offset	M0:S.79	286	R/W	0 to (Scale Factor-1)
Group 5 Position	M0:S.21	170	R/W*	0 to (Scale Factor-1)

*Not while running

Screen

MAIN SCREEN **SEL** ▼ to CONFIG MENU **SEL** ▼ to INITIAL SETUP **SEL** ▼ to OUTPUT GROUPS **SEL**

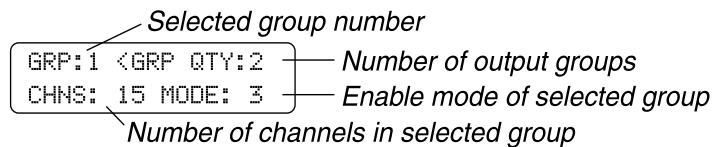

Begin by moving the cursor to GRP QTY and entering the number of groups desired, followed by ENT (or use the INC/DEC keys).

Next, move the cursor to GRP and enter "0" followed by ENT.

Move the cursor to CHNS and enter the number of output channels to be included in Group 0, followed by ENT (or use the INC/DEC keys).

Move the cursor to MODE and enter the operating mode for the group from zero to five, followed by ENT (or use the INC/DEC keys). See Section 6 for an explanation of the operating characteristics of each mode.

Move the cursor back to GRP and repeat these steps for each group to be programmed.

When output channels are divided into groups, the appearance of the Main Screen will change slightly. See MAIN SCREEN for details.

(continued)

Output Groups (cont'd)

Description

This function allows you to divide output channels into groups, and assign operating modes to the groups. Operating modes provide a powerful tool for relating output channel operation to sensor signals or other inputs. Incorporating modes into a control system can greatly improve line efficiency, reduce scrap, and improve control accuracy between machine sections at high speeds. See Section 6 for a complete explanation of the uses and applications of operating modes.

Establishing Groups

When dividing outputs into groups, keep these rules in mind:

- Output channels are assigned to groups sequentially. Group 0 will begin with Output 0 and include the specified number of outputs; Group 1 will begin with the next output and continue sequentially for its specified number of outputs; and so on. The last group will automatically include all of the remaining outputs.
- You can establish as many as six groups or as few as one.
- Each group can operate in any of the six modes.

Grouping Example 1—All Outputs in One Group

Output Group	Includes Outputs
0	0 thru 31

Grouping Example 2—Two Groups

Output Group	Includes Outputs
0	0 thru 3
1	4 thru 31

Grouping Example 3—Three Groups

Output Group	Includes Outputs
0	0 & 1
1	2 & 3
2	4 thru 31

Also see MAIN SCREEN, GROUP OFFSET, and GRP POS DISP.

Output Maps

Backplane

<i>PL-1746 Function Name</i>	<i>SLC 500 File Address</i>	<i>Mapping Index Number</i>	<i>Read/Write Capability</i>	<i>Valid Range for Data</i>
Output Word 0 Map #	M0:S.192	512	R/W	0-32767
Output Word 1 Map #	M0:S.193	514	R/W	0-32767
Output Word 2 Map #	M0:S.194	516	R/W	0-32767
Output Word 3 Map #	M0:S.195	518	R/W	0-32767
Output Word 4 Map #	M0:S.196	520	R/W	0-32767
Output Word 5 Map #	M0:S.197	522	R/W	0-32767
Output Word 6 Map #	M0:S.198	524	R/W	0-32767
Output Word 7 Map #	M0:S.199	526	R/W	0-32767

Screen

MAIN SCREEN **SEL** ▼ to MAPPING MENU **SEL** to OUTPUT MAP REGS **SEL**

```
REG# OUTPUT MAP#  
  0              0
```

Use INC/DEC keys to select the desired mapping register. Use select, then the numeric keypad, to enter the mapping index number followed by the ENT key. See the section on Remote I/O and Register Mapping for more information. These registers allow the user to select M0 or M1 file registers for writing through the eight Output file registers.

Description

This screen displays the output mapping registers. When a mapping index number is placed in one of these registers, the corresponding M0 or M1 register will be mapped into the indicated output file register.

Output Status

Backplane

<i>PL-1746 Function Name</i>	<i>SLC 500 File Address</i>	<i>Mapping Index Number</i>	<i>Read/Write Capability</i>	<i>Valid Range for Data</i>
Input Word 0 PL-1746 Output Channel 0-15 Status, 1bit/channel	I:S.0	None	R/O	0=Off 1=On
Input Word 1 PL-1746 Output Channel 16-31 Status, 1bit/channel	I:S.1	None	R/O	0=Off 1=On
Force Outputs On Channels 0-31, 1bit/channel	M0:S.256- M0:S.257	640- 642	R/W	1=Force Active 0=Force Inactive
Force Outputs Off Channels 0-31, 1bit/channel	M0:S.264- M0:S.265	656- 658	R/W	1=Force Active 0=Force Inactive

Screen

MAIN SCREEN **SEL** ▼ to TEST MENU **SEL** ▼ to I/O STATUS **SEL** ▼ to OUTPUT STATUS **SEL**

```

OUTPUTS 76543210
0-7<   00000000
    
```

Press the SEL key to change the set of outputs displayed.

Press ◀ to access Output 0, causing the “0” to blink. Press **SEL** to turn this output on. The “0” will change to a “1”. Select other desired outputs by pressing ▶ or ◀. If the output is already on, a “1” will be present instead of a “0”. So, the “1” will change to a “0” when the output is forced.

Press **ESC** to return to output number selection. Outputs will remain forced until you leave the Output Status screen.

Description

This screen shows the On/Off state of the output channels, and it allows the outputs to be forced.

Setting a bit in one of the force outputs on registers will cause the corresponding output to turn ON. Setting a bit in one of the force outputs OFF registers will cause the corresponding output to turn OFF. Force OFF takes precedence over force ON. If outputs are forced from the keyboard, the forcings are cleared when the status menu is exited and the bits in these registers will be cleared.

Password

Backplane

<i>PL-1746 Function Name</i>	<i>SLC 500 File Address</i>	<i>Mapping Index Number</i>	<i>Read/Write Capability</i>	<i>Valid Range for Data</i>
Master Password	M0:S.106	340	R/W	0-9999
Setup Password	M0:S.105	338	R/W	0-9999
Operator Password	M0:S.104	336	R/W	0-9999

Screen

MAIN SCREEN SEL ▼ to PASSWORD SEL

```
PASSWORD: *****  
LEV:NONE INP:OFF
```

— Password entry area
— Keypad programming terminal input status
— Current programming level (hardware or software)

Enter a password through the numeric keypad followed by ENT. As you press the number keys, the asterisks will be replaced by dashes. If you make a mistake, press CLR to erase the last key you pushed.

```
PASSWORD: --***  
LEV:NONE INP:OFF
```

— Dashes replace asterisks as numbers are entered

```
PASSWORD: *****  
LEV:MAS INP:OFF
```

— Dashes change back to asterisks with ENT
— Enable level shown if number matches programmed password value

Description

This screen provides an area to enter a password. It also shows the current programming access level and the status of the Programming Enable terminals on the back of the keypad.

There are three programming access levels; OPERATOR, SETUP, and MASTER. The codes that correspond to each level are established in the ENABLE CODES screen.

If you enter a password that has been programmed through ENABLE CODES, the keypad will function at the corresponding programming level. See ENABLE CODES for a description of the various levels.

If either of the programming enable terminals on the back of the keypad is active when a password is entered, the programming level will be whichever is greater.

When programming operations are completed, enter a password value of "0", then ENT to clear the enable level.

If a keypad is left unattended with an active password, the access code will clear after five minutes of keypad inactivity and the keypad will revert to the "Normal Display" mode.

There is no password for the backplane. All configuration and setpoint data is always accessible.

Also see ENABLE CODES.

Per Channel Enable

Backplane

<i>PL-1746 Function Name</i>	<i>SLC 500 File Address</i>	<i>Mapping Index Number</i>	<i>Read/Write Capability</i>	<i>Valid Range for Data</i>
Per-Channel Operator Access Channels 0-31, 1 bit/channel	M0:S.280-M0:S.281	688-690	R/W	0=Operator Accessible 1=Operator Inaccessible

Screen

MAIN SCREEN **SEL** ▼ to PROGRAM ENABLE **SEL** ▼ to PER CHN ENABLE **SEL**

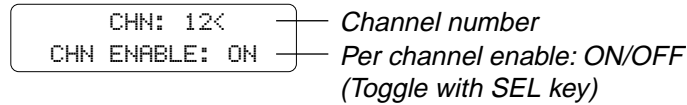

Press the INC/DEC keys, or use the numeric keys and ENT.
Press the SEL key to toggle the enable ON or OFF.

Description

This screen is used to enable Operator Level access to individual output channels. PER CHN ENABLE is used in conjunction with the ENABLE OPTIONS screen to assign Operator Level access to selected programming functions.

Also see ENABLE OPTIONS.

Program Copy

Backplane

<i>PL-1746 Function Name</i>	<i>SLC 500 File Address</i>	<i>Mapping Index Number</i>	<i>Read/Write Capability</i>	<i>Valid Range for Data</i>
Program Copy Destination Program	M0:S.769	1666	R/W*	0-47
Program Copy Source Program	M0:S.768	1664	R/W*	0-47
Program Copy Command/Status	M0:S.770	1668	R/W* *Not while running	Bit 15 Error Bit 14 Source Pgm Error Bit 13 Dest Pgm Error Bit 12 Reserved Bits Error Bit 11 Dest Pgm Not Empty Error Bit 10-1 Reserved Bit 0 Execute/Busy

M0:S.770/0 Execute Program Copy. This bit remains on until the copy is complete or an error occurs. Either condition will clear this bit.

M0:S.770/1-10 Reserved bits. Writing a one to any of these bits will cause a reserved bits error (see M0:S.770/12).

M0:S.770/11 This bit is set if the destination program already has pulses in it.

M0:S.770/12 Reserved bits. This bit is set if a one is written to any of the reserved bits.

M0:S.770/13 The Destination Program error bit is set if the destination program is out of the range.

M0:S.770/14 The Source Program error bit is set if the source program is out of the range.

(Continued)

Program Copy (cont'd)

M0:S.770/15 The Error bit is set if any of the above error bits is set. This provides a single bit to test for command success/failure. When the Error Bit is set, test the other bits to determine the exact cause.

When the error bit M0:S.770/15 is set, the Command Error bit and the Any Error bit are set in the Programming Error Register (I:S.7). To clear the error condition, toggle the Clear Error bit (O:S.0/8) ON. No additional commands will be accepted until the error bits are cleared.

Screen

MAIN SCREEN **SEL** ▼ to FUNCTION **SEL** ▼ to PGM COPY **SEL**

```
OUTPUTS 76543210
0-7      00000000
```

The Program Copy function consists of four screens:

```
SRC PROGRAM:----<
```

— *Program to be copied from*

```
DST PROGRAM:----<
```

— *Destination to be copied to*

```
DST PROGRAM: 6<
EXECUTE<
```

— *Move cursor to EXECUTE, then press SEL to copy program*

```
DST PROGRAM: 6
COMPLETE<
```

— *COMPLETE indicates program successfully copied*

Use the numeric keys and SEL to enter program numbers.

During programming, the cursor keys allow you to move between the Source and Destination screens to allow you to change values before selecting EXECUTE.

Description

Program Copy allows you to copy all the pulses in the source program to the destination program. It may be easier to copy an existing program and modify it, than to enter a completely new program.

Pulse Copy

Backplane

<i>PL-1746 Function Name</i>	<i>SLC 500 File Address</i>	<i>Mapping Index Number</i>	<i>Read/Write Capability</i>	<i>Valid Range for Data</i>
Pulse Copy Program	M0:S.704	1536	R/W	0-47
Pulse Copy Channel	M0:S.705	1538	R/W	0-31
Pulse Copy On (Train Start)	M0:S.706	1540	R/W	0 to (Scale Factor-1)
Pulse Copy Off (Train End)	M0:S.707	1542	R/W	0 to (Scale Factor-1)
Pulse Copy Count (Number of Pulses)	M0:S.708	1544	R/W	1 to ((Off-On)/2)
Pulse Copy Duration (of each pulse)	M0:S.709	1546	R/W	1 to ((Off-On)/2*Count)
Pulse Copy Command/Status	M0:S.710	1548	R/W* *Not while running	Bit 15 Error Bit 14 Program Error Bit 13 Channel Error Bit 12 On > Scale Factor Error Bit 11 Off > Scale Factor Error Bit 10 Overlap Error Bit 9 Duration Error Bit 8 Reserved Bits Error Bit 7-1 Reserved Bit 0 Execute/Busy

- M0:S.710/0 Execute Pulse Copy. This bit remains on until the copy is complete or an error occurs. Either condition will clear this bit.
- M0:S.710/1-7 Reserved bits. Writing a one to any of these bits will cause a reserved bits error (see M0:S.710/8).
- M0:S.710/8 Reserved bits. This bit is set if a one is written to any of the reserved bits.
- M0:S.710/9 The Duration Error bit is set if the pulse duration is < 1.
- M0:S.710/10 The Overlap Error bit is set if the number of pulses created exceeds one half the scale factor, which would cause pulses to be overlapped.
- M0:S.710/11 The Off Pulse Copy value exceeds the scale factor.
- M0:S.710/12 The On Pulse Copy value exceeds the scale factor.
- M0:S.710/13 The channel error bit is set if channel value is out of range.
- M0:S.710/14 The program error bit is set if program value is out of range.
- M0:S.710/15 The Error bit is set if any of the above errors is set. This provides a single bit to test for command success/failure. When the Error bit is set, test the other bits to determine the exact cause.

When the error bit M0:S.710/15 is set, the Command Error bit and the Any Error bit are set in the Programming Error Register (I:S.7). To clear the error condition, toggle Clear Error bit (O:S.0/8) ON. No additional commands will be accepted until the error bits are cleared.

(continued)

Pulse Copy (cont'd)

Screens

Menu Path

MAIN SCREEN **SEL** ▼ to FUNCTION **SEL** ▼ to PULSE COPY **SEL**

The Pulse Copy function consists of eight screens:

- | | | |
|---------------------------|---|---|
| PROGRAM: ---< | — | <i>Program to add pulses to;
Enter number, then SEL to go to next screen</i> |
| CHANNEL: ---< | — | <i>Channel to add pulses to;
Enter number, then SEL to go to next screen</i> |
| ON: ---< | — | <i>"On" time of leading edge of first pulse;
Enter number, then ENT & SEL to go to next screen</i> |
| OFF: ---< | — | <i>"Off" time of trailing edge of last pulse;
Enter number, then ENT & SEL to go to next screen</i> |
| COUNT---< | — | <i>Total number of pulses to be added;
Enter number, then ENT & SEL to go to next screen</i> |
| DURATION: ---< | — | <i>Duration of each pulse added;
Enter number, then ENT & SEL to go to next screen</i> |
| DURATION: 35
EXECUTE< | — | <i>Move cursor to EXECUTE, then press SEL to
generate pulses. To review values before executing,
move cursor to top row and press SEL as needed</i> |
| DURATION: 35
COMPLETE< | — | <i>COMPLETE indicates pulses have been generated</i> |

Example

Generate a train of pulses as follows:

<u>Pulse</u>	<u>On</u>	<u>Off</u>
1	0	50
2	100	150
3	200	250
4	300	350
5	400	450
6	500	550
7	600	650
8	700	750
9	800	850
10	900	950

Each pulse is 50 increments wide, separated from the next pulse by 50 increments.

Description

Pulse Copy allows you to program a series, or "train" of pulses into a channel without having to enter the On and Off edges for each pulse. The Pulse Copy function prompts you for the beginning and ending edges for the pulse train; the number of pulses in the train; and the duration of a pulse. Pulse Copy then divides the designated portion of the resolver cycle into the specified number of pulses, evenly dividing the unused portion of the segment between the pulses.

(continued)

Pulse Copy (cont'd)

PROGRAM: ---< — Program to add pulses to;
Enter number, then SEL to go to next screen

CHANNEL: ---< — Channel to add pulses to;
Enter number, then SEL to go to next screen

ON: 0< — "On" time of leading edge of first pulse;
Enter 0, then ENT & SEL to go to next screen

OFF: 950< — "Off" time of trailing edge of last pulse;
Enter 950, then ENT & SEL to go to next screen

COUNT 10< — Total number of pulses to be added;
Enter 10, then ENT & SEL to go to next screen

DURATION: 50< — Duration of each pulse added;
Enter 50, then ENT & SEL to go to next screen

DURATION: 50
EXECUTE< — Move cursor to EXECUTE, then press SEL to
generate pulses.

DURATION: 35
COMPLETE< — COMPLETE indicates pulses have been generated

Go to SETPOINTS to confirm the pulse train:

<-P-> CH: 1 <EDG
ON: 0 OF: 50 — Move cursor to OF and use arrow keys to
review pulse setpoints

Pulses Used

Backplane

PL-1746 Function Name	SLC 500 File Address	Mapping Index Number	Read/Write Capability	Valid Range for Data
Pulses Total	M0:S.26	180	R/O	1252 Units without Shift Register (no -S in model #) 787 Units with Shift Register (-S in model #)
Pulses Used	M0:S.27	182	R/O	0 to Pulses Total

Screen

MAIN SCREEN **SEL** ▼ to TEST MENU **SEL** ▼ to SYSTEM INFO **SEL** ▼ to PULSES USED **SEL**

TOTAL: 1200 — Total number of pulses available for programming
USED: 64 — Number of pulses programmed into all channels of all programs

Description

The number of pulses shown as "Used" is the sum of all pulses that are programmed into all channels of all programs. The "Total" value is the number of pulses that can be stored in non-volatile EEPROM memory. The difference between the two numbers is the number of pulses available for programming. The number of pulses programmed into all channels of all programs cannot exceed the value displayed as Total. There are no values that can be changed in this screen.

Pulse Edit

Backplane

<i>PL-1746 Function Name</i>	<i>SLC 500 File Address</i>	<i>Mapping Index Number</i>	<i>Read/Write Capability</i>	<i>Valid Range for Data</i>
Pulse Edit Program	M0:S.896	1920	R/W	0-47
Pulse Edit Channel	M0:S.897	1922	R/W	0-31
Pulse Edit On (Leading Edge)	M0:S.898	1924	R/W	0 to Scale Factor
Pulse Edit Off (Trailing Edge)	M0:S.899	1926	R/W	0 to Scale Factor
Pulse Edit Pulse Index (within channel)	M0:S.900	1928	R/W	0 to (Pulse Quantity-1)
Pulse Edit Pulse Quantity (within channel)	M0:S.901	1930	R/O	0 to (Scale Factor/2)
Pulse Edit Command/Status	M0:S.902	1932	R/W	Bit 15 Error Bit 14 Program Error Bit 13 Channel Error Bit 12 On > Scale Factor Error Bit 11 Off > Scale Factor Error Bit 10 Pulse Index Error Bit 9 Reserved Bits Error Bit 8-5 Reserved Bit 4-1 Command (see below) Bit 0 Execute/Busy Commands (bits 4-1): 0000 Read 0001 Write 0010 Increment On 0011 Decrement On 0100 Increment Off 0101 Decrement Off 0110 Increment Both 0111 Decrement Both 1000 Increment All 1001 Decrement All 1010 Change On 1011 Change Off 1100 Reserved 1101 Reserved 1110 Reserved 1111 Reserved

(continued)

Note: See Appendix for Output Pulse Programming information.

Pulse Edit (cont'd)

Command /Status Register Bits	M0:S.902/0	Execute Pulse Edit. This bit remains on until the edit is complete or an error occurs. Either condition will clear this bit.
	M0:S.902/1 to 4	Command bits specify which command to execute as shown in the COMMANDS table. Using a reserved code will cause a reserved bits error.
	M0:S.902/5 to 8	Reserved bits. Writing a one to any of these bits will also cause a reserved bits error (see M0:S.902/12).
	M0:S.902/9	Reserved bits. This bit is set if a one is written to any of the reserved bits.
	M0:S.902/10	The Pulse Number error bit is set if the pulse number in a channel with more than one pulse exceeds the actual number of pulses in that channel.
	M0:S.902/11	The Pulse Edit Off value exceeds the scale factor.
	M0:S.902/12	The Pulse Edit On value exceeds the scale factor.
	M0:S.902/13	The Channel error bit is set if the channel value is out of range.
	M0:S.902/14	This Program error bit is set if the program value is out of range.
	M0:S.902/15	The Error bit is set if any of the above errors is set. This provides a single bit to test for command success/failure. When the Error bit is set, test the other bits to determine the exact cause.

Screen No screen is available. This function is programmed through the backplane only. To edit pulses via the keypad, see the Pulses Section.

Description The selected pulse is created, modified or deleted. A pulse is created if no other pulse has the specified program/channel. A pulse is deleted when the on and off values are both zero. If a pulse is found that matches the specified program/channel, it's on and off setpoints are changed to the values specified. When the error bit M0:S.710/15 is set, the Command Error bit and the Any Error bit are set in the Programming Error Register (I:S.7). To clear the error condition, toggle the Clear Error (O:S.0/8) ON. No additional commands will be accepted until the error bits are cleared.

Pulse Edit Command Requirements

The READ command requires the following information: PULSE EDIT PROGRAM and PULSE EDIT CHANNEL. If there are multiple pulses in the channel, the PULSE EDIT PULSE NUMBER selects which pulse to read. The first pulse is number zero. The PL-1746 responds to this command by providing the PULSE EDIT ON, PULSE EDIT OFF and PULSE EDIT PULSES IN CHANNEL values.

The WRITE command requires the following information: PULSE EDIT PROGRAM, PULSE EDIT CHANNEL, PULSE EDIT ON, and PULSE EDIT OFF. If there are no pulses in the specified channel, a new pulse will be created. The PL-1746 responds to this command by creating the specified pulse. If the channel already has at one or more pulses in it, multiple pulses will be created. If the PULSE EDIT ON and PULSE EDIT OFF values are both zero, all pulses in the specified channel will be deleted.

All the INC and DEC commands for ON, OFF, and BOTH require the following information: PULSE EDIT PROGRAM and PULSE EDIT CHANNEL. If there are multiple pulses in the channel, the PULSE EDIT PULSE NUMBER is also required. The PL-1746 responds to these commands by performing the specified operation on the PULSE EDIT ON value, PULSE EDIT OFF value, or both.

The INC ALL and DEC ALL commands require the following information: PULSE EDIT PROGRAM and PULSE EDIT CHANNEL. The PL-1746 responds to these commands by performing the specified operation on all the pulses in the channel.

The CHANGE ON and CHANGE OFF commands require the following information: PULSE EDIT PROGRAM, PULSE EDIT CHANNEL, and depending on which command, PULSE EDIT ON, or PULSE EDIT OFF. The PL-1746 responds to these commands by storing the specified ON or OFF edge value. If the PULSE EDIT ON value is the same as the PULSE EDIT OFF value, that pulse will be deleted leaving other pulses in the same channel unchanged.

Pulses

Screen

MAIN SCREEN **SEL** ▼ to PULSES **SEL**

When PULSES is selected, a preliminary screen specifies the program whose channels will be programmed.

```
PGM NUMBER: <
```

— *Program to view or modify*

The active program is displayed, but any other program can be specified by using the numeric keys or INC and DEC to choose a program, then pressing SEL to move to pulse programming.

<-P-> indicates multiple pulses in channel

```
<-P-> CH:1<EDG  
ON: 90 OF: 270
```

```
CH: 1 <EDG  
ON: 90 OF: 270
```

Blank if only 1 pulse in channel
Channel
Pulse mode
OFF edge
ON edge

Channel to Edit

Use the numeric keypad and ENT to select the channel to program.

- **Channels 90 through 95 are special channels used for Output Grouping and Modes. See Chapter 6 for details.**

Pulse Edges

Use the left and right arrow keys to move between the ON and OFF edges.

- If a channel has more than one pulse, you may view the other pulses by pressing the right cursor key when viewing the OFF edge, or by pressing the left cursor key when viewing the ON edge.
- If a channel contains no pulses, the ON and OFF edges will be “0.”
- If a channel is always on, both the ON and OFF edges will be “1.”

```
CH:1 EDG  
ON: 0< OF: 0
```

— *ON and OFF edges both 0 if no pulses in channel. Both 1 if channel always ON*

```
CH:1 EDG  
ON: ---< OF: ---
```

— *Enter ON edge, then ENT or right cursor to OF. Enter OFF edge, then press ENT.*

Adding a Pulse

You may add a new pulse to a channel by pressing the SEL key when the cursor points to either the ON or the OFF edge.

The display will change to show blank ON and OFF edges; the cursor will point to the ON edge. Enter the ON edge through the numeric keypad, and then press the ENT key or the right cursor to move to the OFF edge. Enter the OFF edge through the numeric keypad and then press the ENT key.

Adding Multiple Pulses

If ON and OFF edges for a pulse are visible on the screen and you press SEL to program a new pulse, the original pulse will remain in the output channel. If the ON or OFF edges entered overlap an existing pulse in the channel, you will see an “Error: Pulse Overlap” message. To abort entering a pulse at any time, press ESC.

Pulses (cont'd)

Changing Pulse Edges

Change an edge value with the numeric keys followed by ENT, or with the INC and DEC keys.

Pulse Modes

The Pulse Mode controls how the INC and DEC keys modify pulses. There are three modes; **EDG** (edge), **PUL** (pulse), and **CHN** (channel.) Change the Pulse Mode by pressing the SEL key when the cursor points to the Pulse Mode.

In **EDG** mode, the INC and DEC keys will affect the selected ON or OFF edge only.

In **PUL** mode, both ON and OFF edges will be incremented or decremented simultaneously.

In **CHN** mode, **all** ON and OFF edges for all pulses in the channel will be incremented or decremented simultaneously.

Deleting a Pulse

A pulse may be deleted by making ON equal to OFF, or vice versa. If there is more than one pulse in the channel, the next pulse will appear in the on/off edges area. If the channel has no more pulses, the ON and OFF edges will both be zero.

Clearing a Channel

To clear a channel of all pulses, enter a new pulse with ON and OFF edges of "0."

Channel Always ON

A channel may be programmed to be on for a full revolution (always on) by entering a new pulse with both ON and OFF =edges equal to "1."

Programming Recommendations

For most installations, before programming edges, it is best to set MACHINE POSITION to zero at the start of a machine cycle. This allows you to jog the machine to various points in the machine cycle where output channels must turn on or off, note these machine positions from the PL-1746 display, and enter them into pulse programming. Pulses programmed in this manner will relate directly to the machine position. If pulses are programmed before MACHINE POSITION is set, and MACHINE POSITION is subsequently changed, the pulses will no longer correlate with the machine zero position. The same logic applies if GROUP OFFSET will be used for individual output groups. Program the group offsets before establishing pulses for the channels in the groups.

Description

This set of screens provides a means to add pulses to channels, edit existing pulses, increment or decrement pulses in one of the three modes, delete pulses, clear a channel, or turn a channel ON all the time.

Rack Quantity

Backplane

<i>PL-1746 Function Name</i>	<i>SLC 500 File Address</i>	<i>Mapping Index Number</i>	<i>Read/Write Capability</i>	<i>Valid Range for Data</i>
Rack Quantity	M0:S.56	240	R/W	0-2 Model C01 N/A C02,C03,C04

Screen

MAIN SCREEN SEL ▼ to CONFIG MENU SEL ▼ to SECONDARY SETUP SEL ▼ to RACK QTY SEL

```
RACK
QTY: 0<
```

— Use the numeric keys followed by ENT to select number of PS-4108 racks connected to the PL-1746.

Description

The PL-1746-C01 can provide very fast output update with the optional PS-4108 I/O rack. Each rack can provide up to 16 output modules and 8 TTL level inputs. The first rack can also provide up to 2 analog outputs.

Also see ANALOG QTY.

Rate Setup

Backplane

<i>PL-1746 Function Name</i>	<i>SLC 500 File Address</i>	<i>Mapping Index Number</i>	<i>Read/Write Capability</i>	<i>Valid Range for Data</i>
Displayed Units	M0:S.51	230	R/W	0=RPM 1=BPM 2=CPM 3=IPM
Decimal Point Location	M0:S.52	232	R/W	0-3
Rate Multiplier	M0:S.53	234	R/W	1-1091
Rate Divisor	M0:S.54	236	R/W	1-63

Screen

Menu Path

MAIN SCREEN **SEL** ▼ to CONFIG MENU **SEL** ▼ to SECONDARY SETUP **SEL** ▼ to RATE SETUP **SEL**

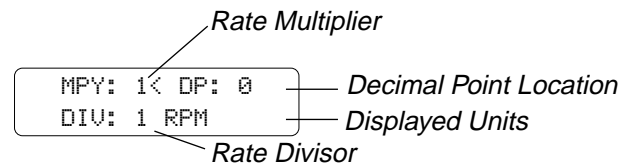

Units—Move the cursor to the “Units” field and use SEL to toggle between values.

MPY & DIV—Move the cursor to MPY or DIV and use the numeric keys followed by ENT to enter a value.

DP—Move the cursor to DP and use SEL to toggle between values.

Following are a few examples of the relationships between multiplier (MPY), divider (DIV), decimal points (DP), actual resolver speed, and displayed resolver speed:

If MPY Is...	And DIV Is...	And DP Is...	Then MPY/DIV Is...	And a Resolver Speed Of...	Is Displayed As...
1	2	0	.5	100 RPM	50 RPM
1	2	1	.5	100 RPM	5.0 RPM
1	2	2	.5	100 RPM	.50 RPM
1	2	3	.5	100 RPM	.050 RPM
1	1	0	1.0	100 RPM	100 RPM
1	1	1	1.0	100 RPM	10.0 RPM
1	1	2	1.0	100 RPM	1.00 RPM
1	1	3	1.0	100 RPM	.100 RPM
2	1	0	2.0	100 RPM	200 RPM
2	1	1	2.0	100 RPM	20.0 RPM
2	1	2	2.0	100 RPM	2.00 RPM
2	1	3	2.0	100 RPM	.200 RPM

Description

The Rate Setup function allows you to configure the RPM display on the Main Screen.

Resolver Mode

Backplane

<i>PL-1746 Function Name</i>	<i>SLC 500 File Address</i>	<i>Mapping Index Number</i>	<i>Read/Write Capability</i>	<i>Valid Range for Data</i>
Resolver Mode N/A C02, C03, C04 Set via DIP switch on plug-in card	M0:S.60	248	R/W* *Not while running	0=Master 1=Slave

Screen

MAIN SCREEN **SEL** ▼ to CONFIG MENU **SEL** ▼ to SECONDARY SETUP **SEL** ▼ to
RESOLVER MODE **SEL**

```
RESOLVER MODE
MASTER<
```

Use SEL to set the opposite mode, followed by ENT to assign the new selection, or ESC to cancel the new selection.

Description

It is sometimes necessary to connect two PL-1746 controls to a single resolver. This function allows one PL-1746 to provide excitation to the resolver (master) and the second PL-1746 to monitor the position of the resolver (slave).

This screen is used to select the resolver mode for PL-1746-C01 ONLY. For C02/C03/C04 the Resolver Mode is set via DIP switch, and the screen/register is read-only.

NOTE: Setting a module to slave mode turns off the reference signal to the resolver. If a reference signal is not supplied by another module, the resolver position and speed data will be random, and (in C02/C03 models) an “EX07 Resolver not OK” message will result.

RPM Update Rate

Backplane

<i>PL-1746 Function Name</i>	<i>SLC 500 File Address</i>	<i>Mapping Index Number</i>	<i>Read/Write Capability</i>	<i>Valid Range for Data</i>
RPM Update Rate	M0:S.49	226	R/W	0=1/s 1=2/s 2=10/s

Screen

MAIN SCREEN **SEL** ▼ to CONFIG MENU **SEL** ▼ to SECONDARY SETUP **SEL** ▼ to
RPM UPD RATE **SEL**

```
RPM UPDATE
RATE: 1/S<
```

Press the SEL key to toggle the selection.

Description

The RPM Update Rate is how often the RPM display on the Main Screen is updated.

Scale Factor

Backplane

<i>PL-1746 Function Name</i>	<i>SLC 500 File Address</i>	<i>Mapping Index Number</i>	<i>Read/Write Capability</i>	<i>Valid Range for Data</i>
Scale Factor	M0:S.32	192	R/W* *Not while running	2-4096

Screen

MAIN SCREEN ▼ to CONFIG MENU ▼ to INITIAL SETUP ▼ to SCALE FACTOR

```

SCALE
FACTOR: 360<
    
```

— Number of increments each revolution is divided into

Note: The PS-6400 keypad may time out if there are a large number of pulses when changing scale factor. Do not cycle power during this operation, or data may be lost.

Description

This function controls the number of increments into which one resolver revolution is divided. A scale factor of 360 (0 to 359) allows the controller to operate in degrees. A higher scale factor allows positions to be programmed more accurately. In some applications the scale factor can be set so each increment equals a unit of linear travel.

When the scale factor is changed, all programmed setpoints are recalculated to convert them to the new scale factor. The keypad/display will be inoperative until the calculations are done.

Note: Speed compensation requires time to respond to accelerations, and longer scale factors increase that response time.

Shift Count

Backplane

<i>PL-1746 Function Name</i>	<i>SLC 500 File Address</i>	<i>Mapping Index Number</i>	<i>Read/Write Capability</i>	<i>Valid Range for Data</i>
Shift Register Models C02,C03 only				
Program 0 Shift Counts (Channels 0-31)	M0:S.920- M0:S.951	1968- 2030	R/W	0-255
Program 1 Shift Counts (Channels 0-31)	M0:S.952- M0:S.983	2032- 2094	R/W	0-255
Program 2 Shift Counts (Channels 0-31)	M0:S.984- M0:S.1015	2096- 2158	R/W	0-255
Program 3 Shift Counts (Channels 0-31)	M0:S.1016- M0:S.1047	2160- 2222	R/W	0-255
Program 4 Shift Counts (Channels 0-31)	M0:S.1048- M0:S.1079	2224- 2286	R/W	0-255
Program 5 Shift Counts (Channels 0-31)	M0:S.1080- M0:S.1111	2288- 2350	R/W	0-255
Program 6 Shift Counts (Channels 0-31)	M0:S.1112- M0:S.1143	2352- 2414	R/W	0-255
Program 7 Shift Counts (Channels 0-31)	M0:S.1144- M0:S.1175	2416- 2478	R/W	0-255
Program 8 Shift Counts (Channels 0-31)	M0:S.1176- M0:S.1207	2480- 2542	R/W	0-255
Program 9 Shift Counts (Channels 0-31)	M0:S.1208- M0:S.1239	2544- 2606	R/W	0-255
Program 10 Shift Counts (Channels 0-31)	M0:S.1240- M0:S.1271	2608- 2670	R/W	0-255
Program 11 Shift Counts (Channels 0-31)	M0:S.1272- M0:S.1303	2672- 2734	R/W	0-255
Program 12 Shift Counts (Channels 0-31)	M0:S.1304- M0:S.1335	2736- 2798	R/W	0-255
Program 13 Shift Counts (Channels 0-31)	M0:S.1336- M0:S.1367	2800- 2862	R/W	0-255
Program 14 Shift Counts (Channels 0-31)	M0:S.1368- M0:S.1399	2864- 2926	R/W	0-255
Program 15 Shift Counts (Channels 0-31)	M0:S.1400- M0:S.1431	2928- 2990	R/W	0-255
Program 16 Shift Counts (Channels 0-31)	M0:S.1432- M0:S.1463	2992- 3054	R/W	0-255
Program 17 Shift Counts (Channels 0-31)	M0:S.1464- M0:S.1495	3056- 3118	R/W	0-255
Program 18 Shift Counts (Channels 0-31)	M0:S.1496- M0:S.1527	3120- 3182	R/W	0-255
Program 19 Shift Counts (Channels 0-31)	M0:S.1528- M0:S.1559	3184- 3246	R/W	0-255
Program 20 Shift Counts (Channels 0-31)	M0:S.1560- M0:S.1591	3248- 3310	R/W	0-255
Program 21 Shift Counts (Channels 0-31)	M0:S.1592- M0:S.1623	3312- 3374	R/W	0-255
Program 22 Shift Counts (Channels 0-31)	M0:S.1624- M0:S.1655	3376- 3438	R/W	0-255
Program 23 Shift Counts (Channels 0-31)	M0:S.1656- M0:S.1687	3440- 3502	R/W	0-255
Program 24 Shift Counts (Channels 0-31)	M0:S.1688- M0:S.1719	3504- 3566	R/W	0-255

Shift Count (cont'd)

Backplane

<i>PL-1746 Function Name</i>	<i>SLC 500 File Address</i>	<i>Mapping Index Number</i>	<i>Read/Write Capability</i>	<i>Valid Range for Data</i>
Program 25 Shift Counts (Channels 0-31)	M0:S.1720- M0:S.1751	3568- 3630	R/W	0-255
Program 26 Shift Counts (Channels 0-31)	M0:S.1752- M0:S.1783	3632- 3694	R/W	0-255
Program 27 Shift Counts (Channels 0-31)	M0:S.1784- M0:S.1815	3696- 3758	R/W	0-255
Program 28 Shift Counts (Channels 0-31)	M0:S.1816- M0:S.1847	3760- 3822	R/W	0-255
Program 29 Shift Counts (Channels 0-31)	M0:S.1848- M0:S.1879	3824- 3886	R/W	0-255
Program 30 Shift Counts (Channels 0-31)	M0:S.1880- M0:S.1911	3888- 3950	R/W	0-255
Program 31 Shift Counts (Channels 0-31)	M0:S.1912- M0:S.1943	3952- 4014	R/W	0-255
Program 32 Shift Counts (Channels 0-31)	M0:S.1944- M0:S.1975	4016- 4078	R/W	0-255
Program 33 Shift Counts (Channels 0-31)	M0:S.1976- M0:S.2007	4080- 4142	R/W	0-255
Program 34 Shift Counts (Channels 0-31)	M0:S.2008- M0:S.2039	4144- 4206	R/W	0-255
Program 35 Shift Counts (Channels 0-31)	M0:S.2040- M0:S.2071	4208- 4270	R/W	0-255
Program 36 Shift Counts (Channels 0-31)	M0:S.2072- M0:S.2103	4272- 4334	R/W	0-255
Program 37 Shift Counts (Channels 0-31)	M0:S.2104- M0:S.2135	4336- 4398	R/W	0-255
Program 38 Shift Counts (Channels 0-31)	M0:S.2136- M0:S.2167	4400- 4462	R/W	0-255
Program 39 Shift Counts (Channels 0-31)	M0:S.2168- M0:S.2199	4464- 4526	R/W	0-255
Program 40 Shift Counts (Channels 0-31)	M0:S.2200- M0:S.2231	4528- 4590	R/W	0-255
Program 41 Shift Counts (Channels 0-31)	M0:S.2232- M0:S.2263	4592- 4654	R/W	0-255
Program 42 Shift Counts (Channels 0-31)	M0:S.2264- M0:S.2295	4656- 4718	R/W	0-255
Program 43 Shift Counts (Channels 0-31)	M0:S.2296- M0:S.2327	4720- 4782	R/W	0-255
Program 44 Shift Counts (Channels 0-31)	M0:S.2328- M0:S.2359	4784- 4846	R/W	0-255
Program 45 Shift Counts (Channels 0-31)	M0:S.2360- M0:S.2391	4848- 4910	R/W	0-255
Program 46 Shift Counts (Channels 0-31)	M0:S.2392- M0:S.2423	4912- 4974	R/W	0-255
Program 47 Shift Counts (Channels 0-31)	M0:S.2424- M0:S.2455	4976- 5038	R/W	0-255

(continued)

Shift Count (cont'd)

Screen

MAIN SCREEN **SEL** ▼ to CONFIG MENU **SEL** ▼ to SECONDARY SETUP **SEL** SHFT COUNT **SEL**

PGM: 0	CHN: 1	—	Output Channel to be ANDed
SHIFT COUNT:	0	—	Shift Count That Will Enable Output Channel

To select the output's channel, program, and shift count, use the numeric keys and ENT, or use the INC and DEC keys.

Input Window

A bit is set in Position "0" of the shift register when the Product Present Input (Terminal IO of the pluggable input header) is energized. A Shift Window is provided to limit the portion of revolution during which the signal will be accepted from Terminal IO. A bit is set in the Shift Register only if Terminal IO becomes energized within that window.

Description

The shift register is a form of electronic memory that sets a "bit" in the zero count of the register when a signal is applied to Terminal IO. Afterwards, each time the position passes the point programmed as the SHIFT POSITION, the register "shifts" the bit to the next higher count. The bit passes along the shift register until, on the 256th shift, the bit is erased.

An output channel can be ANDed with any count in the shift register, so that the channel is enabled only when a bit appears in that count. In this way, output channels can be enabled up to 255 revolutions after Terminal IO is energized.

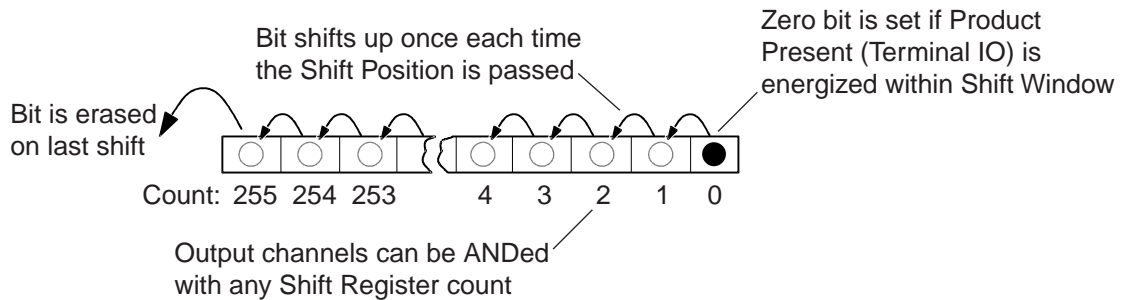

- ANDing an output channel with Count "0" is the same as turning Shift Register ANDing off. The shift register will have no affect on channel operation.
- Any number of output channels can be ANDed to a single shift register count.
- Shift Register ANDing, Input ANDing, and Motion ANDing can be combined for any given output channel.

Shift Position

Backplane

<i>PL-1746 Function Name</i>	<i>SLC 500 File Address</i>	<i>Mapping Index Number</i>	<i>Read/Write Capability</i>	<i>Valid Range for Data</i>
Shift Position	M0:S.917	1962	R/W	0 to (Scale Factor-1)

Screen

Menu Path

MAIN SCREEN **SEL** ▼ to FUNCTION MENU **SEL** ▼ to SHIFT POSITION **SEL**

SHIFT POS: 350 — *Position at which Shift Register will shift.*

Use INC and DEC, or the numeric keys and ENT.

Description

The Shift Position is the point in the encoder revolution at which the shift register data shifts. Also see Shift Count and Shift Window.

Shift Register Display

Backplane

Reset the shift register by setting O:S.0/9.

Screens

MAIN SCREEN **SEL** ▼ to TEST MENU **SEL** to I/O STATUS MENU **SEL** ▼ SHIFT REGISTER **SEL**

063 SHFT-REG 000 — *Shift register contents positions 0-63*
 0000000000000000 — *16 hexadecimal digits*

127 SHFT-REG 064 — *Shift register contents positions 64-127*
 0000000000000000 — *16 hexadecimal digits*

191 SHFT-REG 128 — *Shift register contents positions 128-191*
 0000000000000000 — *16 hexadecimal digits*

255 SHFT-REG 192 — *Shift register contents positions 192-255*
 0000000000000000 — *16 hexadecimal digits*

All four parts of the Shift Register can be viewed by using the left/right arrow keys to change to the next part. Note that the contents of the individual positions cannot be changed.

Description

The Shift Register screen shows the current contents of the Shift Register. To reset all positions in the Shift Register press the CLR key.

Shift Window

Backplane

PL-1746 Function Name	SLC 500 File Address	Mapping Index Number	Read/Write Capability	Valid Range for Data
Window On	M0:S.918	1964	R/W	0 to (Scale Factor-1)
Window Width	M0:S.919	1966	R/W	0 to (Scale Factor-1)

Screen

Menu Path

MAIN SCREEN **SEL** ▼ to CONFIG MENU **SEL** ▼ to SECONDARY SETUP **SEL** SHFT WINDOW **SEL**

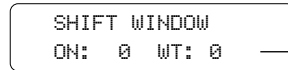

Beginning of window = ON; WT is the width (size)

Use numeric entry, followed by ENT, to change ON and WT.

Description

The point in a revolution at which Terminal IO of the pluggable input header enters a bit into bit 0 of the Shift Register is programmed through the Shift Window screen. When programming Shift Position and the Shift Window, remember the following:

Don't Place the Shift Position at the Start of the Shift Window

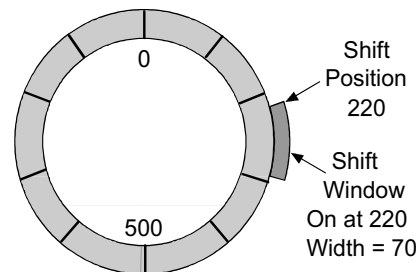

When a pulse starts at the beginning of the Shift Window, as shown here, the pulse will be enabled as soon as a bit is shifted into the programmed shift count.

Although the output will function normally on this revolution, a small output spike may occur on the following revolution as the bit is shifted to the next shift count.

The Product Present input (terminal IO) is rising edge triggered. The leading edge of the signal must appear in the Shift Window for a bit to be set in the Shift Register.

Edge Sensitivity of the Product Present Input

(Shift Window programmed "on" at 650, "width" of 100 in this example; Shift Position = 0)

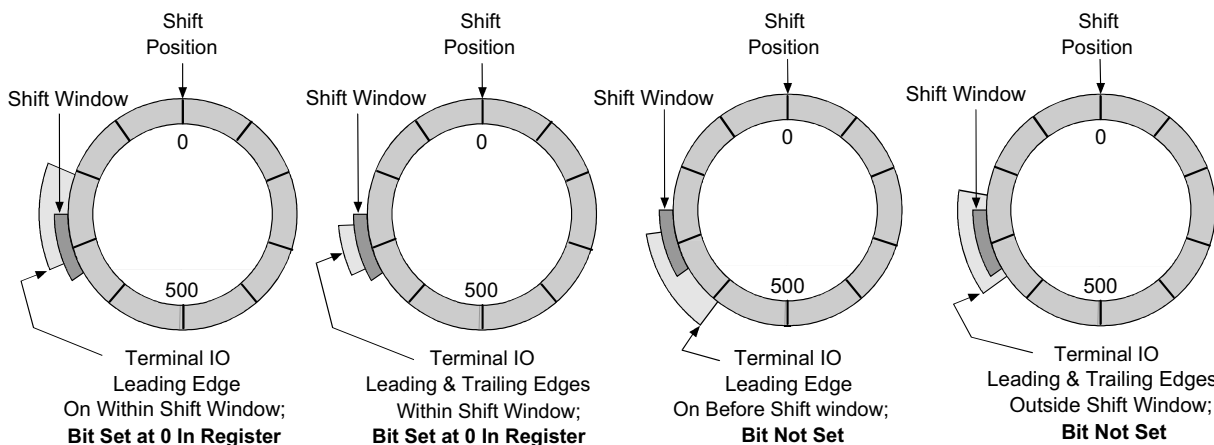

Shift Window (Cont'd)

When the Shift Window overlaps the shift position as shown here, two problems may occur.

One Product, Two Bits: Due to variations in conditions, sensors sometimes generate more than one pulse for a product. If the product sensor sends a pulse early in the window, that pulse will shift when the encoder reaches the shift position. If the sensor sends a second pulse for the same product after the shift position, a second bit will be set for the same product.

Inconsistent Timing: Some products may appear early in the Shift Window, while others appear late. For early products, a bit will be set, then immediately shifted at the shift position. For late products, a bit will be set after the shift position, and a full revolution will occur before the bit shifts to 1.

In most applications, programming Shift Window to overlap the Shift Position will cause problems.

Shift Window Overlaps Shift Position—Not Recommended!

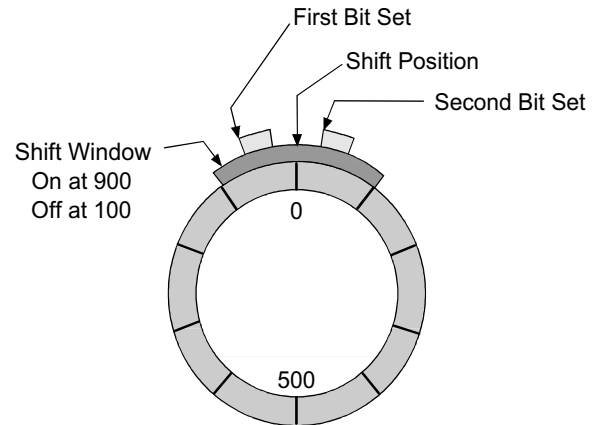

Software Version

Backplane

<i>PL-1746 Function Name</i>	<i>SLC 500 File Address</i>	<i>Mapping Index Number</i>	<i>Read/Write Capability</i>	<i>Valid Range for Data</i>
Base Revision	M0:S.4	136	R/O	0-32767
Major Revision	M0:S.3	134	R/O	0-32767

Screen

Menu Path

MAIN SCREEN **SEL** ▼ to TEST MENU **SEL** ▼ to SYSTEM INFO **SEL** ▼ to SOFTWARE VERSION **SEL**

```
MAJOR REV: 1.75
BASE REV: 1.17
```

There are no values that can be changed in this screen.

Description

The Software Version screen displays the revision number of the firmware contained within the controller. This information may be useful if the unit needs to be returned for service.

Speed Compensation

Backplane

<i>PL-1746 Function Name</i>	<i>SLC 500 File Address</i>	<i>Mapping Index Number</i>	<i>Read/Write Capability</i>	<i>Valid Range for Data</i>
Leading Edge Channels 0-31, 1word/channel	M0:S.384- M0:S.415	896- 958	R/W	-999.9 to 999.9
Trailing Edge Channels 0-31, 1word/channel	M0:S.448- M0:S.479	1024- 1086	R/W	-999.9 to 999.9

Screen

MAIN SCREEN **SEL** ▼ to FUNCTION MENU **SEL** ▼ SPEED COMP **SEL**

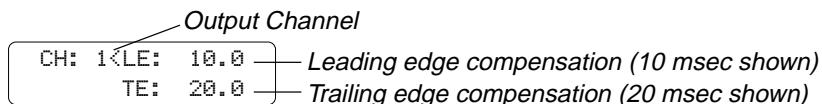

To change output channels, move the cursor to the channel number and enter a new one. You may also INC or DEC the channel number.

To change speed comp values, use the numeric keys or INC and DEC. To enter tenths of msec, use the decimal point. When entering whole ms values, the decimal point is not needed: "12 ENT" will result in a value of 12.0.

To program negative speed comp, press the +/- key **after** entering a number but **before** pressing ENT. You may also decrement a value below zero.

Note: Speed compensation requires time to respond to accelerations, and large scale factors increase that response time.

Description

Speed Compensation advances or retards selected outputs a specified amount of time at any machine speed.

Some devices such as pneumatic cylinders and glue guns require a fixed amount of time to perform their function. As a machine speeds up, these devices need to be actuated earlier in the cycle in order to complete their action at the required time. Speed compensation automatically advances the pulses of specified output channel(s) as the machine speeds up, maintaining proper synchronization at all speeds. See Chapter 5 for a detailed discussion of speed compensation.

Speed compensation is programmed by entering the response time of the output device in milliseconds (.001sec). The output will always turn on this number of ms before the programmed ON position is reached, and turn off this number of ms before the programmed OFF position is reached. As speed increases, the number of degrees of advance will automatically increase to maintain the number of ms of advance.

Negative Speed Comp

Negative values of speed compensation cause an output channel to lag its programmed machine position by the specified number of msec. See Chapter 5 for details on applying negative speed compensation.

Also see Speed Comp Mode.

Speed Comp Mode

Backplane

<i>PL-1746 Function Name</i>	<i>SLC 500 File Address</i>	<i>Mapping Index Number</i>	<i>Read/Write Capability</i>	<i>Valid Range for Data</i>
Speed Comp Mode	M0:S.35	198	R/W	0=ONE 1=L/T

Screen

MAIN SCREEN **SEL** ▼ to CONFIG MENU **SEL** ▼ to INITIAL SETUP **SEL** ▼ to SPEED COMP MODE **SEL**

```
SPEED COMP
MODE: ONE
```

Press SEL key to toggle between ONE and L/T. Press ENT to confirm your selection.

Description

Speed Comp Mode determines whether standard or leading/trailing edge speed compensation is in effect. When the Speed Comp Mode is ONE, the same value of speed comp is used for both leading and trailing edges. When the Speed Comp Mode is "L/T", the leading and trailing edges of a pulse may have different values of speed comp.

Also see SPEED COMPENSATION.

Timed Outputs

Backplane

<i>PL-1746 Function Name</i>	<i>SLC 500 File Address</i>	<i>Mapping Index Number</i>	<i>Read/Write Capability</i>	<i>Valid Range for Data</i>
Time (ms) Channels 0-31, 1 word/channel	M0:S.320- M0:S.351	768- 830	R/W	0-9999

Screen

MAIN SCREEN **SEL** ▼ to FUNCTION MENU **SEL** ▼ to TIMED OUTPUTS **SEL**

```
CHANNEL: 1
TIME(ms): 20
```

Use numeric entry or INC/DEC to change CHANNEL. Use numeric entry to set TIME in milliseconds.

Description

Any four outputs can be programmed to time out rather than remain on until an OFF setpoint is reached. This makes the output duration constant regardless of machine speed. If the OFF setpoint is reached before the specified time has elapsed, the timing will be aborted and the output will turn off immediately.

Once an output times out, it will not turn on until the next ON setpoint is reached. Each timed output can have a unique time delay length.

A timed output must be programmed with ON and OFF position setpoints in order for output timing to take effect.

If the machine is rotating in the reverse direction, timed outputs will energize when the OFF edge of the pulse occurs.

Toggle RPM

Backplane

<i>PL-1746 Function Name</i>	<i>SLC 500 File Address</i>	<i>Mapping Index Number</i>	<i>Read/ Write Capability</i>	<i>Valid Range for Data</i>
Toggle RPM	M0:S.50	228	R/W	0-9999

Screen

MAIN SCREEN SEL ▼ to CONFIG MENU SEL ▼ to SECONDARY SETUP SEL ▼ to
TOGGLE RPM SEL

```
TOGGLE  
RPM: 50
```

Use the numeric keys and ENT to enter a new value, or use INC and DEC to change an existing value.

Description

Toggle RPM is the resolver speed at which the Position display on the Main Screen will disappear. At speeds below the Toggle RPM the Position display will be visible; at speeds above the Toggle RPM the Position will not be shown.