

General Troubleshooting

Troubleshooting Introduction

This section of the manual contains information which covers both programming and hardware troubleshooting. The controller does identify common programming errors and hardware problems with flashing error messages. Lists of these error messages are found on the next two pages (pages 7-2 & 7-3). If the controller is displaying a flashing error message, look it up in the error message lists and take the recommended steps to correct it.

The troubleshooting section also contains information on

special programming functions that can be used to force outputs on manually, monitor input status, monitor actual resolver position, and test the keyboard hardware. Also, alternate functions are described, which allow all of the control's programming, or all of the output setpoints, to be erased. Be careful when using these functions.

The last page (page 7-9) of the troubleshooting section shows how the transistor output array chips can be replaced in the field should one or more of them become damaged.

Common Troubleshooting Problems

The remainder of this page describes some commonly encountered problems along with likely causes. In many cases, the likely causes are programming errors. Wiring, blown fuses and other causes are also covered where applicable. If you are unable to solve a problem after going through this section, call the Electro Cam factory for assistance.

A. Control Position Value(s) go in Wrong Direction Relative to Machine Direction.

1. Check FCN 101 "dr" for the correct direction of rotation.
2. Check resolver wiring (page 3-1).

B. Controller Position Value(s) do not Match Machine Position.

1. Verify that Shaft Position is correct (FCN 101-"SP").
2. Program FCN 2 or FCN 6 to correct controller position.

C. Controller Completely Dead - No LEDs Lit on Keyboard.

1. Check input power fuse.
2. Check 20-30 Vdc input power present.

D. Outputs not Cycling at Correct Machine Positions

1. Check that correct program number is active.
2. Check the setpoints of the output(s) in question.
3. Verify that control position matches machine position.

E. All Transistor Outputs Not Operating.

1. Check that correct program number is active.
2. Use FCN 200 (page 7-5) to manually force on one of the transistor outputs. Determine if the output is on (check load device status or use a meter). If it is on, there is probably a programming problem (if not on go to step 3). Verify that the output setpoints are correctly programmed. Other possible programming causes are timed outputs (FCN 5), motion ANDing (FCN 107), output modes (FCN 109), and enable input ANDing (FCN 110).
3. Check the transistor output fuse.
4. Check transistor 10-30 Vdc input power present.

F. Some Transistor Outputs Not Working.

1. Check that correct program number is active.
2. Use FCN 200 (page 7-5) to manually force on one of the transistor outputs that is not working. Determine if the output is on (check load device status or use a meter). If it is on, there is probably a programming problem (if not on go to step 3).

Verify that the output setpoints are correctly programmed. Other possible programming causes are timed outputs (FCN 5), motion ANDing (FCN 107), output modes (FCN 109), and enable input ANDing (FCN 110).

3. Check the transistor array chips of the outputs that are not functioning (details on page 7-9).

G. Some Module Output(s) Not Working.

1. Check that correct program number is active.
2. Use FCN 200 (page 7-5) to manually force on one of the module outputs in question. Observe the LED built into the module to determine if it is on. If it is on, there is probably a programming problem (if not on go to step 3). Verify that the output setpoints are correctly programmed. Other possible programming causes are timed outputs (FCN 5), motion ANDing (FCN 107), output modes (FCN 109) and enable input ANDing (FCN 110).
3. If the LED was not on when the output was forced on, using FCN 200, try another module before proceeding to step 4.
4. Check output module fuses of modules where the LED is cycling but the load device is not energizing.
5. Check that load power is present in the circuit and correctly wired.

H. Analog Output Not Working.

1. Check that FCN 101 "nA" (number of analog outputs) is programmed for the correct number of analog outputs.
2. Check that analog output module is located in the correct module position according to FCN 101 "nA".
3. Check that FCN 1 "Ao" (analog offset) and "AH" (analog high RPM) are correctly programmed.
4. Check correct wiring of analog output.
5. Verify that analog load device is within specifications for the analog module.
6. Try a different analog output module.

I. Serial Communication Not Working.

1. Check FCN 104 programming regarding "ct" (comm type), "cS" (comm speed) and "cA" (comm address). Host device and controller must use matching values for these items.
2. Check communication cable wiring (pages 3-14 and 3-15).

Mechanical Problems

If the resolver is generating erratic RPM or position readings, or the position appears to be shifting periodically with respect to the machine cycle, check the mechanical coupling between the resolver and the machine.

If the coupling is not slipping, loosen the coupling and rotate the resolver shaft in both directions with sudden, jerky

motions. If the controller displays unusual position or RPM readings, the resolver may need to be replaced.

Resolvers cannot be repaired in the field. If a unit fails, do not disassemble it. Return it to the factory for replacement.

Electrical Problems

Page 3-2 shows the wiring diagrams for Electro Cam Corp. resolvers and cables. If any wire in one of the three individually shielded pairs becomes disconnected, the following error message will appear on the keypad/display:

“E10 -rES” Resolver Fault

The output channels will immediately be disabled until the resolver is reconnected. Press ECS to clear the error message.

Note that ESC will clear the message and restore access to keypad programming even if the resolver has not been reconnected.

The following procedure should be conducted when the resolver is not functioning and/or the controller is indicating an “E10-rES” error message.

1. Verify that all electrical connections at each end of the resolver cable are secure.

2. Disconnect the cable at the controller. Measure the resistance between all wires on the connector. The paired wires should each have the resistance shown in the figure below, while the resistance between every other combination of wire should be infinite. If the resistance values are correct, the controller may need to be replaced.

3. If the resistance values in step 2 are incorrect, the problem may be in the cable or in the resolver. Disconnect the cable at the resolver and measure the resistance at the resolver pins. The paired wires should each have the resistance shown in the figure below, while the resistance between every other combination of wire should be infinite. If the resistance values are correct, the cable is bad. If the resistance values are wrong, the resolver should be replaced.

Programming Error Messages

Introduction to Programming Error Messages

Programming error messages indicate that an attempted programming step was invalid. The exact message flashing defines why the programming attempted was not acceptable. Except for the first error message shown, "E0 EErr", the control will continue to operate the outputs normally while flashing programming error messages are present.

These Programming Error Messages do not indicate that there is something wrong with the control. They indicate that invalid programming is being attempted. The flashing System Error Messages described on the next page indicate electrical hardware problems not related to programming.

Programming Error Message Descriptions

"E0 EErr" EEPROM Programming Error

The Checksum associated with the Function programming (controller's global configuration) was found to be incorrect when the control powered up. This problem is usually caused by the control powering down within four seconds after a programming change is made (non-volatile memory was being updated when power was lost). Outputs will be disabled until the error condition is cleared.

SOLUTION: Press any key to clear the flashing error message. All configuration programming (Functions) will be returned to the Factory Defaults, but setpoint information will remain unchanged. It will be necessary to reprogram all functions that were altered from the Factory Defaults. (See page 7-7, Alt FCN 7000, for a listing of Factory Defaults.)

"E1 OLAP" Pulse Overlap

The output pulse that was just created or incremented/decremented overlaps or touches another pulse that already exists on the same output channel. Therefore, it was not entered. Also, if one edge of a pulse is incremented/decremented until it becomes equal to the other edge, an "E1 OLAP" error will occur.

SOLUTION: Press any key to clear the flashing error message. Use VIEW keys to review the setpoints that are already programmed on this channel to determine the cause of the overlap condition.

"E2 run" Item Can Not be Programmed While Running

While the resolver was turning, an attempt was made to change a programmed item that cannot be changed unless the resolver is stationary. Example - Items which cannot be changed while in motion are: Direction of Rotation (FCN 101 - dr), Scale Factor (FCN 101 - SF), Output Grouping (FCN 108), and Enable Input Modes (FCN 109).

SOLUTION: Press any key to clear the flashing error message. Stop the machine (resolver) while making the program change.

"E4 -Pro" Programming Not Enabled

A programming change was attempted when the corresponding level of programming access was not enabled. There are three levels of programming access - see page 4-5 of this manual for details.

SOLUTION: Press any key to clear the flashing error message. Enable the appropriate level of programming access and make the necessary changes.

"E5 8888" Number Out of Range

An attempt was made to enter a number that exceeds allowable limits for the item being programmed. Some examples are: a setpoint value that exceeds the scale factor, a channel number that exceeds 25, the number of output groups exceeding 6 (FCN 108), etc.

SOLUTION: Press any key to clear the flashing error message. Enter a valid value for the item being programmed.

"E7-dEF" Too Many Outputs Allocated

An attempt was made to allocate more than 25 outputs in FCN 108.

SOLUTION: Press any key to clear the flashing error message. Review Function 108 to find the cause of the problem.

"E9 tdE" Too Many Timed Outputs

An attempt was made to program more than 4 Timed Outputs.

SOLUTION: Press any key to clear the flashing error message.

"E10-rES" Resolver Fault

See page 7-2 for detailed information.

"E11-ScE" Too Many Speed Compensated Channels

An attempt was made to program more than 16 speed compensated outputs.

SOLUTION: Press any key to clear the flashing error message.

System Error Messages

Introduction to System Error Messages

System errors occur when conditions are detected within the controller that can cause unreliable operation. Rather than allowing the control to continue operating, **all outputs will be disabled and an error message displayed whenever system error conditions occur.**

The cause of a system error must be determined and corrected before reliable controller operation can be guaranteed. Contact the Electro Cam factory for assistance whenever system error messages repeat.

System Error Message Descriptions

“E0 FAtL” Memory Fault

A problem with random access memory has been detected and the unit cannot function properly. Memory circuitry in the controller is not functioning properly.

SOLUTION: The control must be returned to factory for repair. Call Electro Cam for further information.

“E1 CHEC” Checksum Error (Checked on Power-up)

The stored checksum value did not match the memory contents when checked on power-up. All outputs will be disabled while this error condition exists. This problem can be caused by severe electrical noise during power-up or hardware failure within the control.

SOLUTION: Remove and restore input power to the controller. If the control repeats the “E1 CHEC” error condition each time it is powered up, hardware within the control is damaged. Call Electro Cam for further information.

“E10 -rES” Resolver Fault

See Page 7-2 for more detailed information.

“E12 -oFd”

This message indicates that the offset mode has been changed to **onE** instead of **EACH**, when the controller is in Mode 1 or 2. See page 6-2, “**nO**”.

SOLUTION: When using Mode 1 or 2, the offset mode should remain on **EACH**.

“CrASH” Watchdog Timer Fault

The Watchdog Timer has timed out, indicating that the controller is not properly executing its program. All outputs will be disabled during this error condition. This problem can be caused by severe electrical noise or hardware failure within the control.

SOLUTION: Remove and restore input power to the controller. If the control repeats the “CrASH” error condition each time it is powered up, hardware within the control is damaged. Call Electro Cam for further information.

If “CrASH” errors occur at intermittent intervals, they are apparently being caused by excessive electrical noise. Check wiring for proper shielding and grounding.

“FATL_AnA” Analog Chip Error

This message indicates that the controller's analog chip has malfunctioned.

SOLUTION: Call Electro Cam for further information.

Note: A bad analog module will not cause this error message.

“FATL_INTN” or “FATL_INT2” Internal Run Errors

These messages indicate that there is a hardware problem with the internal circuitry. All outputs will be disabled.

SOLUTION: Call Electro Cam for further information.

“LinEFAiL” Input Power Voltage Low

The DC input power operating the controller dropped below normal operating voltage, causing the controller to stop functioning.

SOLUTION: Control will come out of “LinEFAiL” condition when input voltage rises to normal range.

“Pb Stuc” Push Button Stuck

If one of the keyboard keys is on when the unit powers up, this message will be displayed. It can indicate that a key is shorted and always on.

SOLUTION: If “Pb Stuc” error message remains or occurs frequently on power up, call Electro Cam for further information.

“StoP” Controller in Stop Mode

When serial communication command 6 (COM_STOP) is sent to the control, it goes into an idle mode and displays the message “StoP”. The Stop mode allows serial information to be written directly into the control's EEPROM memory, thus allowing rapid loading of program information. The PLuSNET DLOAD (download) program first puts the control in the Stop mode before sending information. When the loading process is complete, it returns the control to the run mode. The control can be left in the Stop mode if the loading process is interrupted before it finishes.

SOLUTION: Power cycle the control to restore normal operation.

I/O Hardware Test Functions

FCN 200: Manually Turn on Individual Outputs

(Master Programming MUST be Enabled)

FCN 200 allows individual outputs to be turned on manually, one at a time. **All other control operations are disabled when FCN 200 is accessed.** This capability can be used to manually test the wiring and output devices connected.

The CHN key is used to select which output will be manually operated, and the ON and OFF keys will turn the selected output on and off. Advancing to another output number or exiting FCN 200 will automatically turn off any output that was manually energized.

Press POS/RPM key to exit FCN 200.

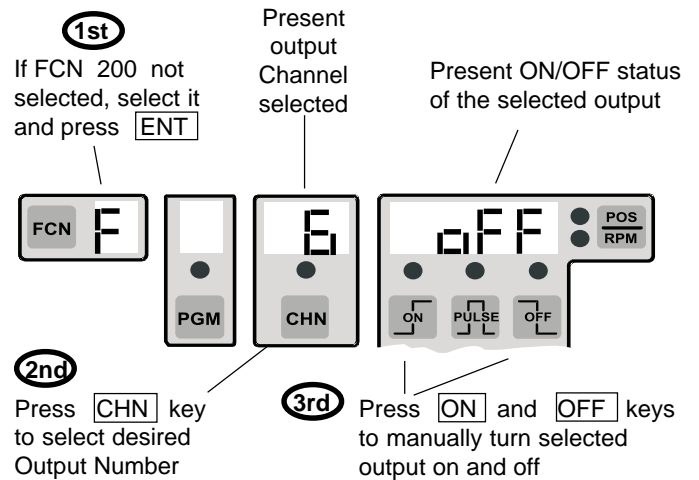

FCN 201: Monitor Status of Inputs

(Master Programming MUST be Enabled)

FCN 201 allows each individual input to be monitored, one at a time. **All other control operations are disabled when FCN 201 is accessed.** This can be used to manually check input wiring and the connected input devices.

The CHN key is used to select which input is being monitored. The status displayed is continuously updated to show the current status of the input.

Press POS/RPM key to exit FCN 201.

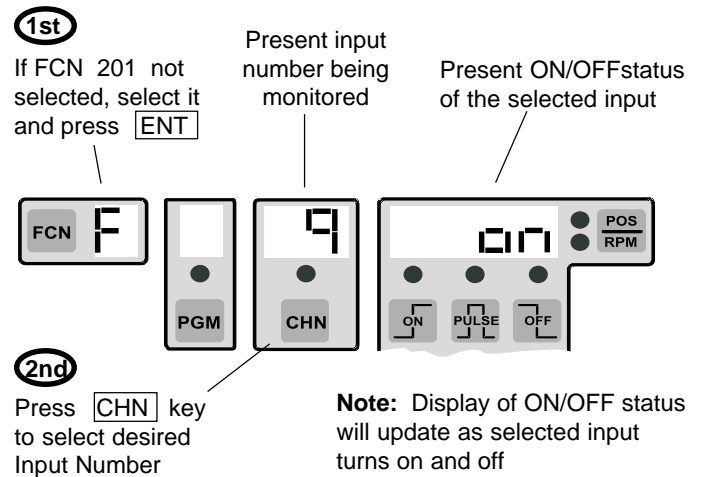

Input Numbers / Functions

1-6	Program Select (1 is LSB)	12	Group 4 Enable
7	Master Program Enable	13	Group 5 Enable
8	Operator Program Enable	14	Group 6 Enable
9	Group 1 Enable	15	First Cycle Enable
10	Group 2 Enable	16	Output Enable
11	Group 3 Enable		

FCN 202: Monitor Actual Resolver Position

(Master Programming MUST be Enabled)

FCN 202 displays the actual resolver position value being output by the resolver. The displayed value does not take into consideration Offset or Direction of Rotation. The resolution of the displayed resolver position is determined by the current Scale Factor as follows:

<u>S.F. Value</u>	<u>Position Resolution</u>
2 - 512	512 (9 bits)
513 - 1024	1024 (10 bits)
1025 - 2048	2048 (11 bits - "H" Option Only)
2049 - 4096	4096 (12 bits - "H" Option Only)

Press POS/RPM key to exit FCN 202.

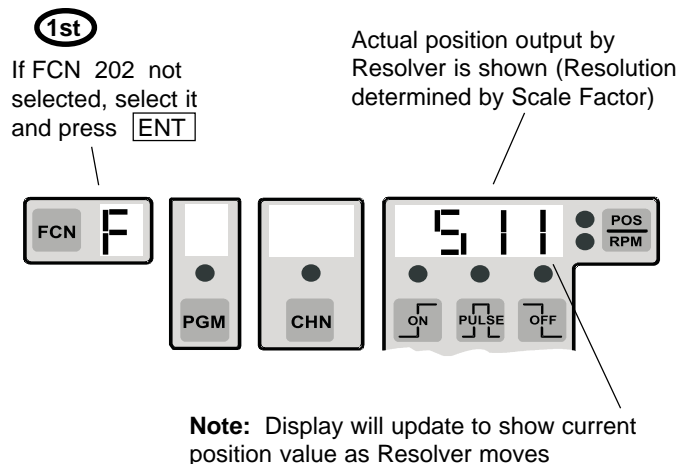

Keyboard Hardware Test Functions

FCN 203: Test All Keyboard LEDs

(Master Programming MUST be Enabled)

FCN 203 lights up all of the keypad LEDs, including the 7 segment displays and their decimal points. This operation can be used to verify that each hardware LED element is operational. The display will go through the following sequence of operation:

1. All 7 segment LED elements light up.
2. Each 7 segment LED lights up in sequence.
3. All indicator LEDs light up (except CPU).
4. CPU indicator LED lights up.
5. LED indicators light up in sequence.
(test returns to step 1)

Hold any key to exit FCN 203.

If FCN 203 not selected, select it and press **ENT**

Displays go through sequences described in text to left

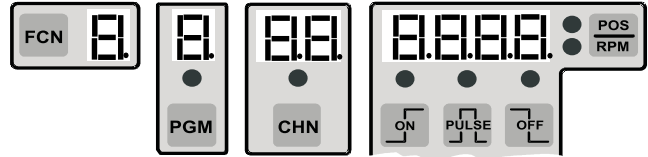

FCN 204: Test Individual Keyboard Keys

(Master Programming MUST be Enabled)

FCN 204 allows individual testing of each key on the keyboard. A 2 digit number is displayed for each key pressed, which confirms that the pressed key is being recognized by the controller. The 2 digit key values are as follows:

Value	Key	Value	Key
99	- No Key or Multiple Keys	65	- FCN
48	- 0	66	- PGM
49	- 1	67	- CHN
50	- 2	68	- ON
51	- 3	69	- PULSE
52	- 4	70	- OFF
53	- 5	71	- <VIEW
54	- 6	72	- VIEW>
55	- 7	73	- <DEC
56	- 8	74	- INC>
57	- 9	75	- ENT
		76	- CLR

1st

If FCN 204 not selected, select it and press **ENT**

2 digit value of key currently pressed

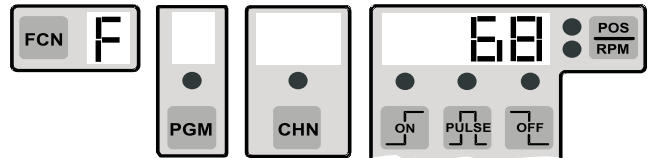

2nd

Press key(s) to be tested. Display will show 2 digit value of key pressed

This example display indicates that the "on" key is pressed because the value "68" is displayed.

Power cycle the control to exit FCN 204.

Alternate Functions

The Alternate Functions (ALT FCNs) allow the control's output setpoint programming to be erased completely and restore all of the function programming to the Factory Default settings if desired. Also, the operation of the control's Watchdog Timer and non-volatile EEPROM circuit and can be tested.

Warning: Output setpoint and function programming can be erased when Alternate Functions are activated.

Ensure that all programmed information is documented or saved to a disk file (units with serial communication) so it can be restored later if needed.

Alternate Functions are activated by using the key stroke sequence illustrated to the right.

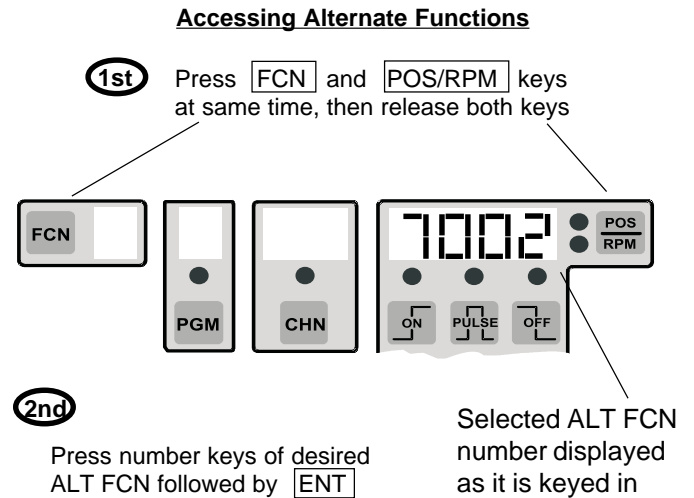

ALT FCN 7000: Restore Factory Defaults and Clear All Output Channel Setpoints

The control will scroll through memory locations shown in position display for approximately 30 seconds. "E0 EErr" display will be flashing when the operation has completed. Press any key to restore normal operation. All Function programming will be reset to Factory Default settings and all "on"/"off" setpoints will be cleared. (Factory Defaults listed to right.)

ALT FCN 7001: Clear all Output Channel Setpoints

The control will scroll through memory locations shown in position display for approximately 30 seconds. A normal display of program number and Position or RPM will be restored when all setpoints have been cleared.

ALT FCN 7002: Watchdog Timer Test

The control will display "rSET" followed by "CrASH" if the watchdog timer functions are operating properly. Press any key to restore normal operation.

If "CrASH" is not displayed when ALT FCN 7002 is activated, call Electro Cam for assistance.

ALT FCN 7999: Extensive EEPROM Test

This function Restores Defaults and Clears All Channel Setpoints. The control will scroll through memory locations shown in the position display for approximately 6-1/2 minutes. "CrASH" will be displayed when the test has completed if no problems were found in EEPROM. Press any key to clear the "CrASH" display, an "E0 EErr" message will then be displayed. Press any key to restore normal operation.

If a problem is found with the EEPROM circuitry, the display will latch up, during the test, with the bad memory location address shown. Call Electro Cam for further information if this happens.

Factory Default Settings

FCN 1	- 1 Lo = 10 1 Hi = 3000 2 LO = 10 2 Hi = 3000	FCN 102	- Sc = onE tb = 1
FCN 2	- Position Value (no offset)	FCN 103	- dd = SPd tr = 0 ru = 1
FCN 3	- PN = 1	FCN 104	- ct = 485 cS = 9600 cA = 1
FCN 4	- All CHN 0	FCN 105	- SE = 1 OE = 2
FCN 5	- All CHN 0	FCN 106	- CHN 1-25 oFF SP = oFF Sd = oFF oF = oFF AP = oFF Sc = oFF to = oFF
FCN 6	- Position Value (no offset)	FCN 107	- CHN 1-25 oFF
FCN 101	- dr = CCL SF = 360 S = Position Value (no offset) nA = 0 nO = EACH rt = Ecc PS = bin	FCN 108	- 1 (grp) 25 (outs)
		FCN 109	- 1 (grp) 0 (Mode)

Retrieving Control's Features Information

Detailed information about the control model and specific features it contains can be retrieved from the keyboard. The functions listed below provide a fool proof way to determine which features are included in the control. Programming access is not required to view these functions since they cannot affect the operation of the control.

FCN 300: "L" & "G" Options, Outputs & Model

The illustration to the right describes the information presented by FCN 300. The "L" option (leading/trailing edge speed comp) and "G" option are optional features on PS-5144 controls, and therefore, do not exist in all units. A given control may have both, one, or neither of these features.

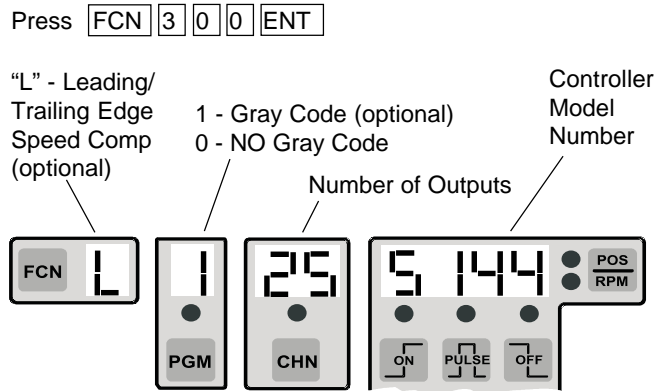

FCN 301: "C" & "H" Options, Software Rev.

The illustration to the right describes the information presented by FCN 301. The "C" option (serial communication) is a standard feature of all PS-5144 controls. The "H" option (high resolution—12 bits) is an optional feature, and therefore, does not exist in all PS-5144 units. The software revision number indicates which version of PS-5144 firm ware is in the control.

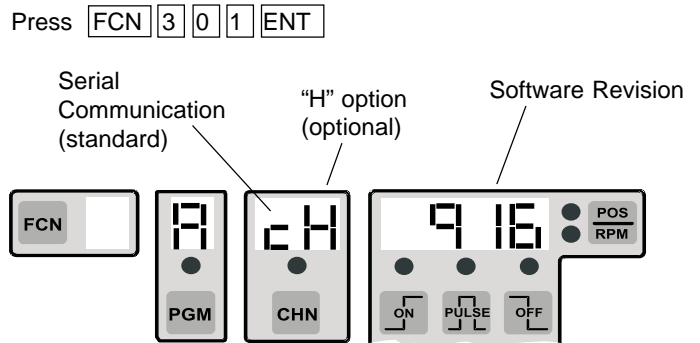

FCN 302: Remote Display and Output Update

The illustration to the right describes the information presented by FCN 302. The "r" indicates that an Electro Cam remote display device can be operated from the RS-485 serial port (standard on all PS-5144 controls).

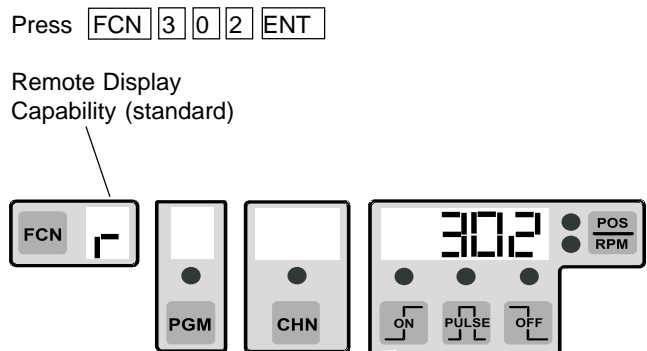

Troubleshooting Transistor Outputs

Sourcing Transistor Outputs: Model# PS-5144-24-P16M09

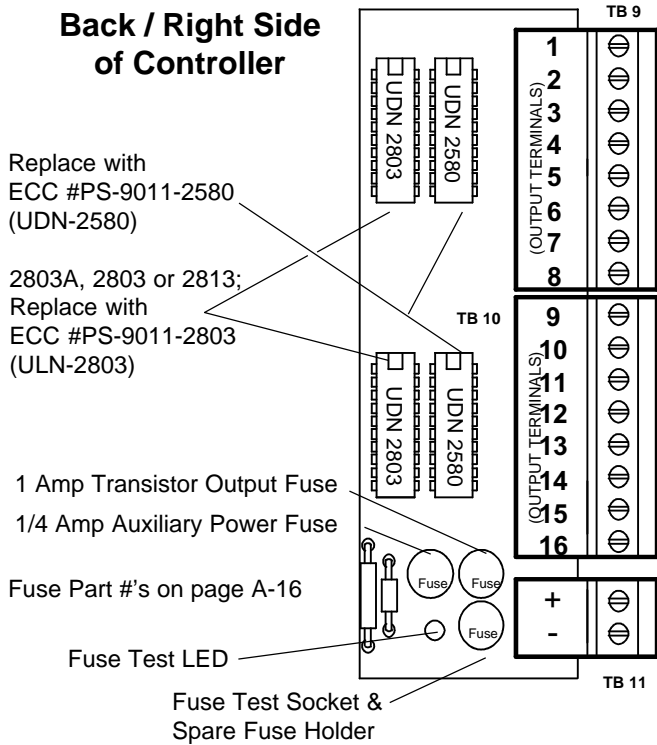

The transistor output circuits are powered by a 10-30 VDC supply connected below the transistor output terminals (page 2-4). **If all of the transistor outputs are not functioning, ensure that 10-30 VDC is applied and that the “1 Amp Transistor Output Fuse” is good.** It can be checked by plugging it into the “Fuse Test Socket” and observing the “Fuse Test LED”.

The transistor array chips are socketed for field replacement. In the event of a wiring error or accidental short circuit, it is possible to damage one or more of the array chips. In these situations, replacing the UDN 2580 chip(s) will usually correct the problem. **Ensure that a short circuit doesn't exist before replacing the chip—be careful not to bend the pins when plugging the chip in.** Each chip operates the 8 transistor outputs immediately to the right of it. **The orientation of the notched end of the chip is critical—ensure that the chip is inserted as shown to the left.**

If replacing the UDN 2580 does not solve the problem, try replacing the ULN 2803A, 2803, or 2813 chip next to it.

Sinking Transistor Outputs: Model# PS-5144-24-N16M09

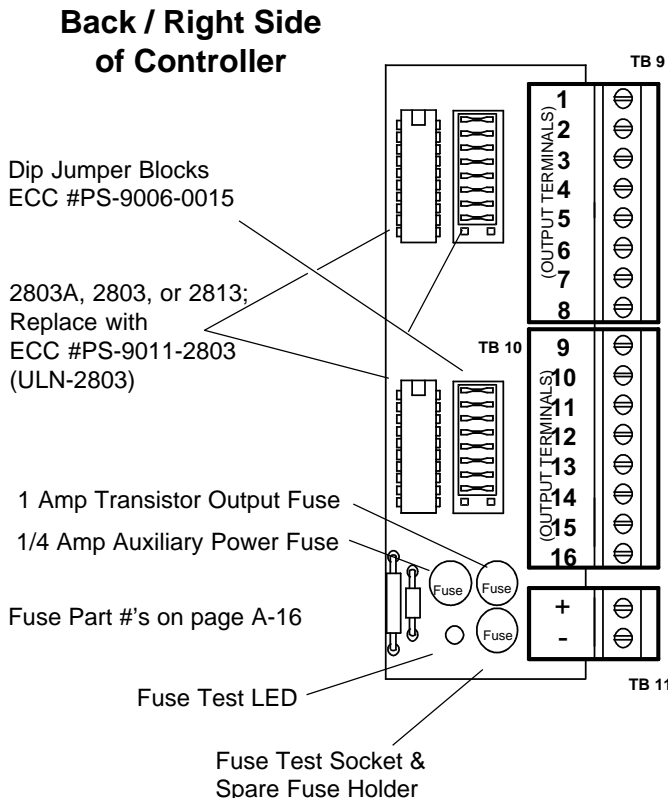

The transistor output circuits are powered by a 10-30 VDC supply connected below the transistor output terminals (page 2-4). **If all of the transistor outputs are not functioning, ensure that 10-30 VDC is applied and that the “1 Amp Transistor Output Fuse” is good.** It can be checked by plugging it into the “Fuse Test Socket” and observing the “Fuse Test LED”.

The transistor array chips and jumper blocks are socketed for field replacement. In the event of a wiring error or accidental short circuit, it is possible to damage one or more of the array chips. In these situations, replacing the ULN 2803A/2813 chip(s) will usually correct the problem. **Ensure that a short circuit doesn't exist before replacing the chip - be careful not to bend the pins when plugging the chip in.** Each chip operates the 8 transistor outputs immediately to the right of it. **The orientation of the notched end of the chip is critical—ensure that the chip is inserted in the direction shown in the illustration to the left.**

Do NOT remove the jumper blocks shown next to the transistor array chips. **If one is removed and needs to be reinserted, ensure that the unjumpered holes in the dip socket are at the bottom, as shown in the illustration.** The jumper block only connects the top eight sets of holes. Connecting the bottom two holes will short out the “10-30 VDC Transistor Input Power” and cause the “1 Amp Transistor Output Fuse” to blow.